



TRAVIS INDUSTRIES
HOUSE OF FIRE

Gas/Pellet Remote Thermostat

SKU 99300646

Compatibility

- All Travis Gas Stoves
- 33 DVI Insert
- 31 DVI Insert
- 564 SS GS
- 864 TRV GS
- 864 ST GS
- 21 TRV GS
- All Travis Pellet Stoves or Inserts

Packing List

- Transmitter
- Receiver
- Receiver Hanger
- Pellet Stove Connector Wires
- "Y" Jumper Wires (for gas appliances)
- Power Cord Adapter (for gas appliances)

FCC Requirements

Warning: Changes or modifications to this unit not expressly approved by the party responsible for compliance could void the user's authority to operate the equipment. This equipment has been tested and found to comply with the limits for a Class B digital device, pursuant to Part 15 of the FCC Rules. These limits are designed to provide reasonable protection against harmful interference in a residential installation. This equipment generates, uses, and can radiate radio frequency energy and, if not installed and used in accordance with the instructions, may cause harmful interference to radio communications. However, there is no guarantee that interference will not occur in a particular installation. If this equipment does cause harmful interference to radio or television reception, which can be determined by turning the equipment off and on, the user is encouraged to try to correct the interference by one or more of the following measures:

- Reorient or relocate the receiver.
- Increase the separation between the equipment and receiver.
- Connect the equipment into an outlet on a circuit different from that to which the receiver is connected.
- Consult the dealer or an experienced radio TV technician for help.

Canadian Equipment Requirements

This digital apparatus does not exceed the (Class A/Class B) limits for radio noise emissions from digital apparatus set out in the Radio Interference Regulations of the Canadian Department of Communications. Le présent appareil numérique n'émet pas de bruits radioélectriques dépassant les limites applicables aux appareils numériques (de la class A/de la class B) prescrites dans le Règlement sur le brouillage radioélectrique édicté par le ministère des Communications du Canada.

This device complies with RSS-210 of Industry and Science Canada. Operation is subject to the following two conditions: (1) this device may not cause interference, and (2) this device must accept any interference, including interference that may cause undesired operation of the device.

Installation Warnings

- ! Shut off power to the appliance and allow it to cool prior to installation.
- ! This kit must be installed by a qualified technician.
- ! All 110 VAC wiring must be done by a qualified electrician and shall be in compliance with local codes and the National Electric Code ANSI/NFPA No. 70 (in the United States), or with the current CSA C22.1 Canadian Electric Code (in Canada).
- ! Do not connect 110 VAC to the gas control valve or on/off switch on gas heaters or the thermostat posts on pellet heaters.

Follow the instructions on the following pages for the type of model being addressed.



TRAVIS INDUSTRIES
HOUSE OF FIRE

Gas/Pellet Remote Thermostat

SKU 99300646

Gas or Pellet Stove Receiver Placement

Place the receiver, with holder, on the back of the heater and route the receiver wires to a location near the on/off switch (see the illustration below).

Connect the receiver power cord to a 110 VAC outlet.

NOTE: On newer gas stoves you may use the power cord adapter to connect the power cord directly to the insert. See "Power Cord Adapter Installation" for details.

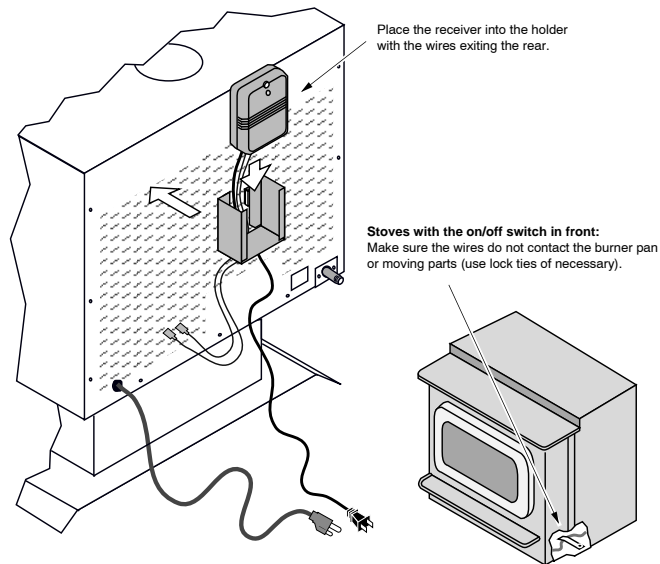

Gas or Pellet Fireplace Insert Receiver Placement

Place the receiver behind the surround panel on the fireplace floor (see the illustration to the right). Route the receiver wires to a location near the on/off switch.

Connect the receiver power cord to a 110 VAC outlet.

NOTE: On the 31 and 33 DVI you may use the power cord adapter to connect the power cord directly to the insert. See "Power Cord Adapter Installation" for details.

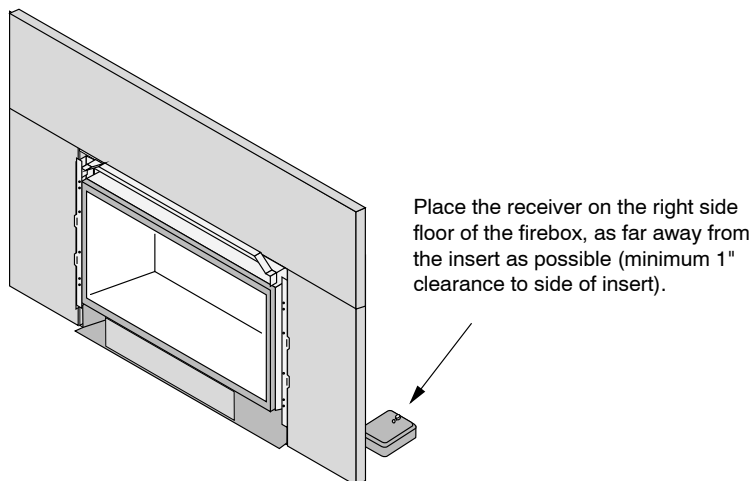



TRAVIS INDUSTRIES
HOUSE OF FIRE

Gas/Pellet Remote Thermostat

SKU 99300646

Gas Fireplace Receiver Placement (564 SS GS, 864 TRV GS, 864 ST GS, 21 TRV GS)

Place the receiver on the fireplace base near the front of the fireplace. Route the receiver wires to a location near the on/off switch. Route the power cord to a location near the power inlet (see "Power Cord Adapter Installation" below).

FOR THE 21 TRV: Remove the control cover and place the receiver to the right of the gas control valve.

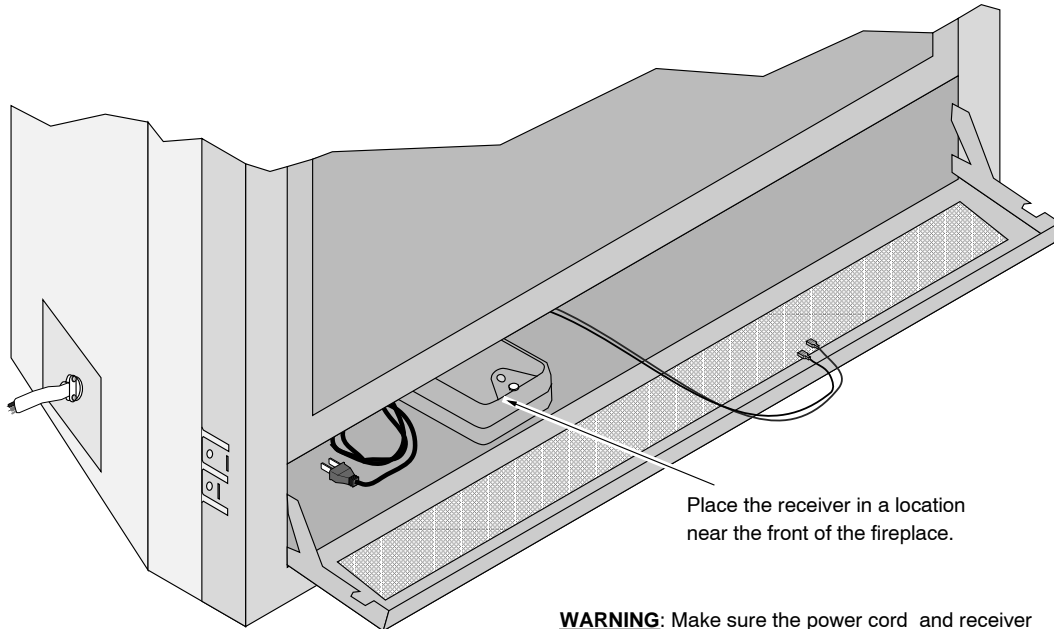

WARNING: Make sure the power cord and receiver wires do not contact the blower (if applicable) or firebox (or other hot surface). Use lock-ties if necessary.

Power Cord Adapter Installation

On newer gas appliances power may be drawn directly from the appliance AC circuit. Connect the receiver power cord to the power cord adapter then attach to the power harness on the appliance (see illustration below). If using a blower you will need to disconnect the blower power lead and attach it to the power cord adapter.

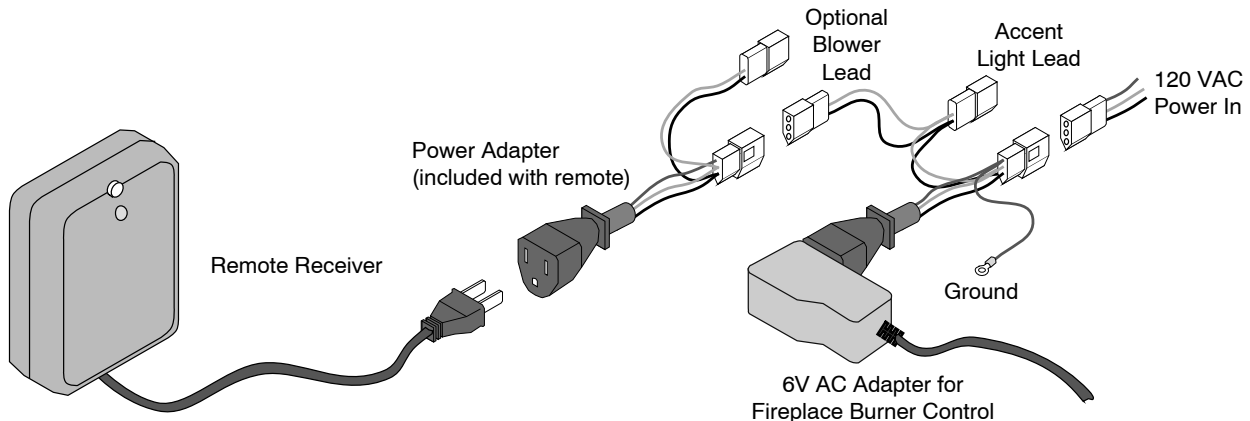



Gas Appliance Receiver Wire Installation

We recommend the receiver wires to be installed in a parallel circuit with the on/off switch. See the directions below for this type of installation.

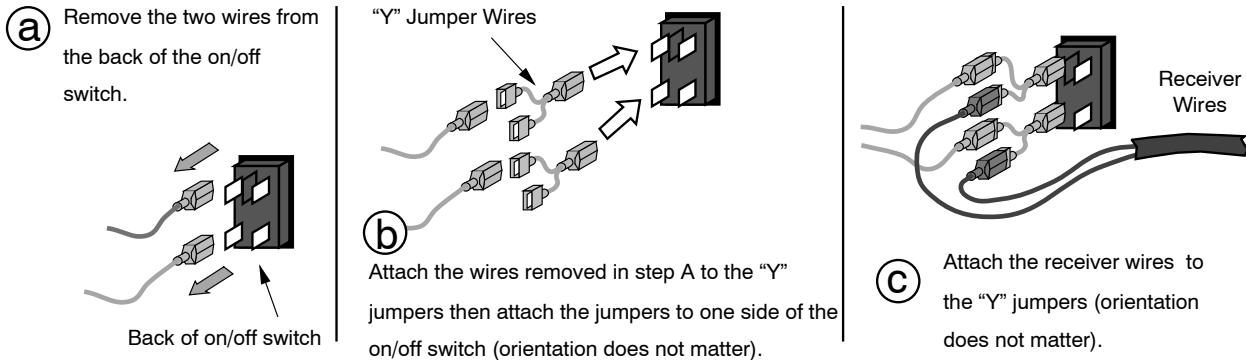

Pellet Appliance Receiver Wire Installation

The receiver wires connect to the back of the pellet control board. See the directions below for installation.

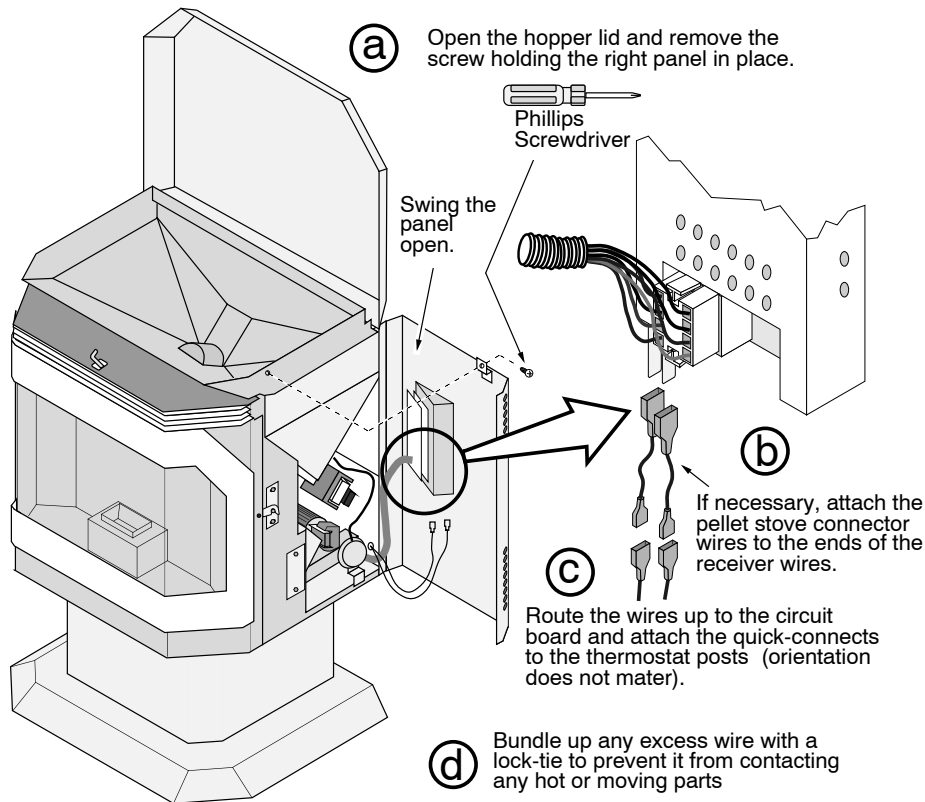



Remote Receiver Calibration

- 1 Remove the cover from the back of the transmitter. Insert three "AAA" batteries into the transmitter as shown. Slide the code switches to a random position on the transmitter.

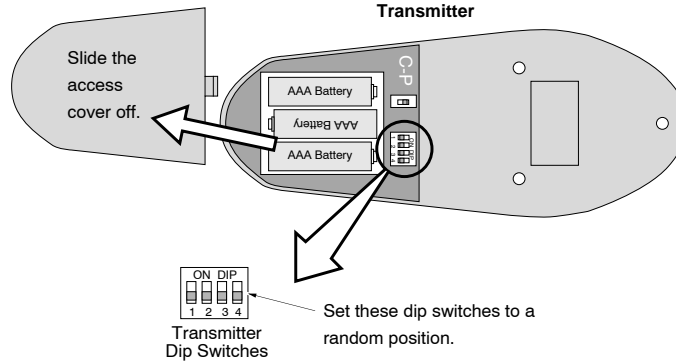

- 2 Plug in the receiver. Position the transmitter within 1 foot of the receiver. The LED indicator panel on the transmitter should be flashing (if not, remove and replace the batteries). Press down any button on the transmitter until the receiver "beeps". This indicates the transmitter and receiver are calibrated on the same radio frequency (if it does not, remove batteries, replace, and repeat this process). Test operation of the remote control.

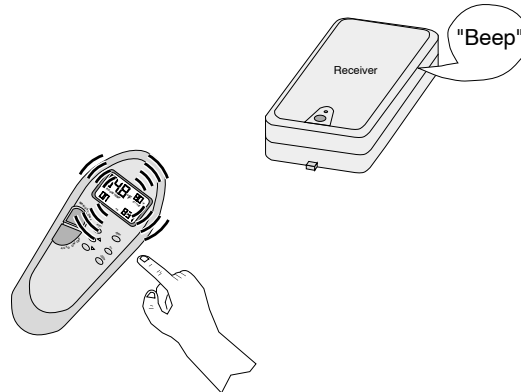

Setting the Time

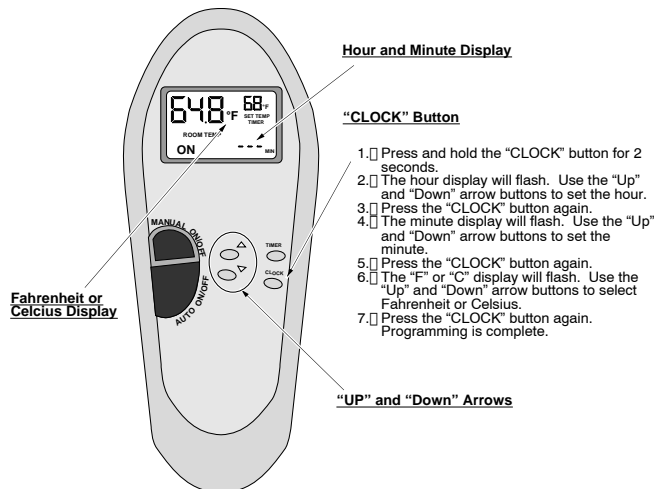



OPERATING INSTRUCTIONS

- NOTE:** This kit must be installed by a qualified technician to work correctly
- NOTE:** On gas appliances the pilot flame must be lit (on standing pilot systems), the gas control valve turned to "ON", and the on/off switch turned to "OFF" for the remote to work correctly.
- NOTE:** On pellet stoves the auger must be primed for the remote to work correctly.
- NOTE:** The remote must be calibrated before it will work (see the instructions on the previous page). If the remote fails to work, try unplugging the remote receiver, plugging it back in, then re-calibrate the remote.

MODES OF OPERATION:

Manual Mode

Use manual mode to turn the heater on and off directly.

TO TURN ON AND OFF:

Use this key to toggle the heater on and off. The display will indicate the status.

NOTE:

- If the room exceeds 90°, the heater will shut off.
- If left on, the heater will shut off after 6 hours.

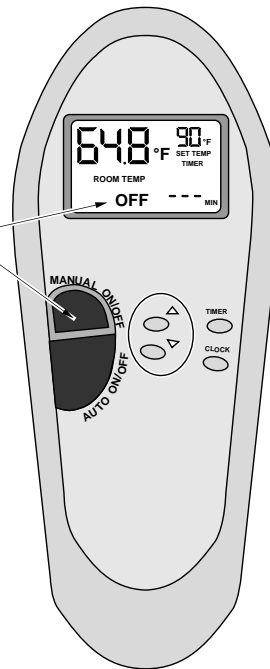



Gas/Pellet Remote Thermostat

SKU 99300646

Auto Mode

Auto mode works like a thermostat, turning the heater on and off to meet the desired temperature.

THERMOSTAT MODE:

Use this key to toggle the thermostat mode. The display will indicate "AUTO" when in thermostat mode.

HINT:

If your heater turns on and off frequently, adjust the flame height down slightly for a more consistent heat output.

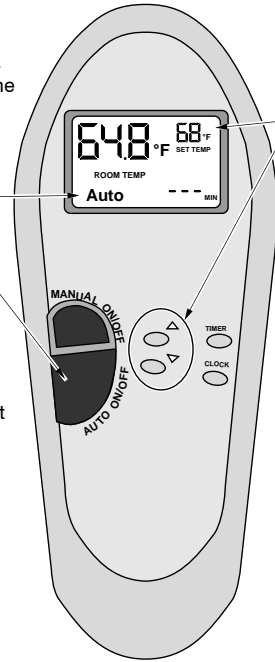

TO ADJUST TARGET TEMPERATURE:

Use the arrow keys to adjust the target temperature to the desired level.

The heater will turn on and off to keep the room temperature near the target temperature.

IMPORTANT NOTES:

- The thermostat has a delay to prevent the heater from turning on and off repeatedly. As a result, the target temperature may be slightly higher (2° or 3°) than the room temperature yet the heater does not turn on – do not adjust the target temperature – the heater will turn on in a few minutes.
- The thermostat is not intended for un-attended use. If the thermostat calls for heat for 6 hours continuously, it will shut off and not turn on until reset.

Timed Mode

Timed mode allows you to turn the heater on for a pre-set period of time.

TIMED OPERATION:

- a) Use the arrow keys to adjust the target temperature to 90°.
- b) Press the "TIMER" button - the " - - - " will start to flash.
- c) Use the arrow keys to set the number of minutes you would like the heater to stay on.

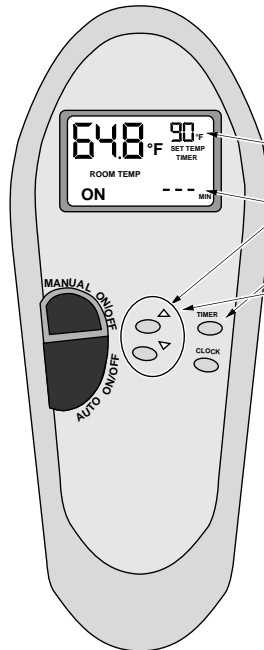

The heater will turn on and stay running for the number of minutes displayed.

NOTE:

If the room exceeds 90°, the heater will shut off.



CHILD PROOF FEATURE:

The child proof switch allows for the remote to be “protected” against undesired use.

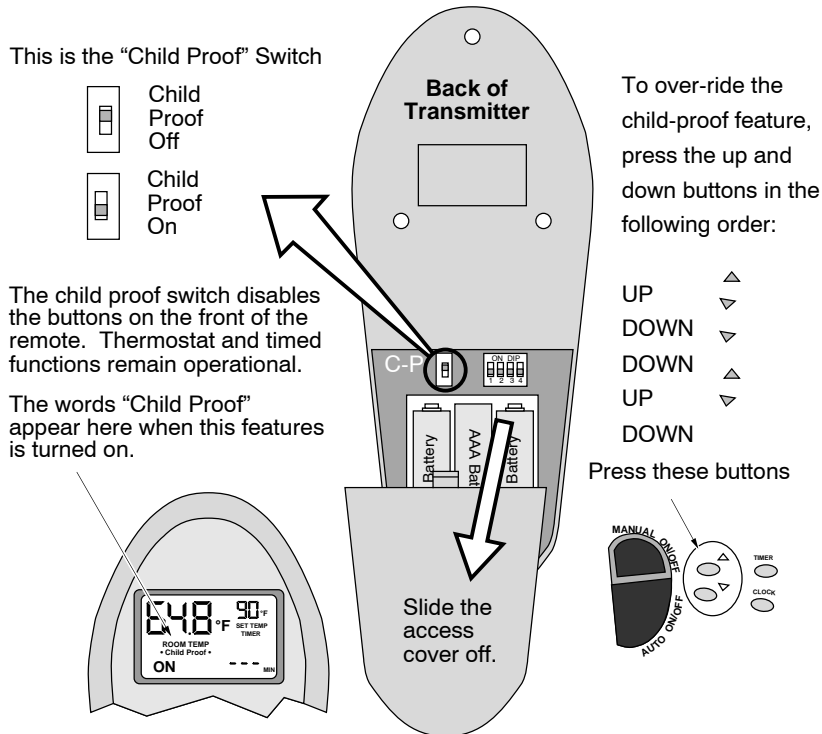

OPERATION WITH DEAD BATTERIES

If the heater is on (any mode) and the batteries go dead, the heater will turn off after 6 hours. To operate the heater, use the switch on the heater to turn the heater on and off.

TURNING THE UNIT OFF WHEN TRANSMITTER IS NOT PRESENT

If at any time you misplace the transmitter and wish to turn the heater off, press the button on top of the receiver. This will over-ride the transmitter and shut the heater off.

OPERATION DURING POWER OUTAGES

If a power outage occurs, the receiver will turn the heater off. Once power is restored, the remote will turn the heater on (if the remote calls for heat) within 30 minutes. If you wish to over-ride the remote and turn the heater on (gas stoves only), turn the on/off switch on the gas heater to "ON".